



**Fluid Power Inc.**

Office: 626-453-8887 Fax: 626-453-8889 E-mail: [tech@dlhfluidpower.com](mailto:tech@dlhfluidpower.com)

## ***Single Acting Dump Trailer Power Unit Owner's Manual***

### **Disclaimer:**

This information is intended for use by a service technician who is familiar with hydraulic components & understands the required safety precautions. Please consult factory for any questions that may not be answered in this document. The installer assumes responsibility for property damage or personal injury or that may result. When operating, installing or performing maintenance on DLH Fluid Power products.

**Please Read Full Equipment Manual  
Before Attempting to Operate or  
Install Equipment.**

### **WARNING:**

**IF THE PRESSURE RELIEF SETTINGS ARE  
TAMPERED WITH THE WARRANTY IS VOID**

## **Safety Precautions**

- Tampering with relief valve
  - ✓ Tampering or adjusting the relief valve will void warranty, and could cause catastrophic failure which could result in equipment damage, severe injury or even death. **Adjusting the relief valve will not increase flow/speed!**
- Hydraulic Fittings & Hoses
  - ✓ Always ensure hydraulic lines are not routed around or across sharp edges that may cause chafing and damage to hose.
  - ✓ Never crack or loosen a hydraulic connection under pressure. Doing so can result in a hydraulic injection.

- ✓ Always follow the manufactures torque specifications for fittings and hoses.

**Warning:** Loosening hydraulic lines under pressure can result in catastrophic failure which could result in equipment damage, severe injury or even death.

***Read OEM manual before attempting to operating power unit***

For more information on hydraulic safety visit

[www.fluidpowersafety.com](http://www.fluidpowersafety.com)

### **Introduction:**

Thank you for choosing equipment a DLH Fluid Power product. Please read this document in its entirety before operating the equipment. Ensure the operator is adhering to the safety precautions at all times.

Failure to follow the safety precautions could result in severe injury or death. Always maintain your power source & power unit to insure trouble free operation.

Please consult the factory or a qualified hydraulic technician before attempting to repair hydraulic equipment. The disassembly of a power unit still under warranty will void the warranty. If you need assistance please consult the factory.

## Unit Identification Information

Model Code:

Serial Number:

Pressure Setting:

### **Unit Identification:**

Before contacting factory for assistance please insure you have the model code & serial number available.

- ✓ *Fill in the unit identification information on this page for future reference.*
- ✓ *Keep this information on or near the equipment, making it readily available when needed.*

### **Identification Locations:**

- The Model Code is located on the identification label that is affixed to the reservoir.
- The Serial Number is located the end-head/ manifold block (serial number may not be visible after installation)
- The pressure setting is located on the identification label affixed the reservoir.

If you are having trouble identifying the unit in question please consult factory for assistance. The model code and serial number are extremely important; they will help us help you answer any questions you might have in a timely manner.

### **Warranty:**

*DLH Fluid Power warrants its power units against defects in design, workmanship and components for a period of 24 months from date of manufacturer.*

*Under this warranty DLH Fluid Power will replace any part of its products, free of charge, only after the product in question has been inspected by DLH Fluid Power or its subsidiaries; and the part is deemed faulty or a manufacturing defect.*

*This warranty does not apply to any product that has been subject to improper installation, unauthorized modification, alteration or repair.*

*DLH Fluid Power is not liable for any accident caused by improper operation, maintenance, abnormal conditions or wear from abnormal use.*

*DLH Fluid Power shall not be liable for loss of time, manufacturing costs, labor, transport, material, loss of profits, consequential damages (direct or indirect), as a result of defective products.*

*DLH Fluid Power responsibility will be limited to the repair or replacement of the defective product or the reimbursement of the price paid at the time it was ordered.*

*Any warranty claim must be presented within 30 days of the manufacturing defect discovery.*

*All shipping charges will subject to the outcome of the warranty evaluation. DLH Fluid Power is not liable for any damages or loss of product incurred during transport.*

### **Hydraulic Fluid:**

ISO viscosity grades 22 to 46 are recommended. Anti wear, antifoaming & rust inhibitor additives are recommended.

(For colder climates ATF Dexron III can be used)

**Do not use synthetic, biodegradable or water base hydraulic fluids.** In most cases these fluids are not compatible with Buna O-rings. Please check fluid compatibility before use.

Tractor hydraulic fluid is not recommended. Most tractor hydraulic fluid has too high of a viscosity & may not be compatible with Buna O-rings.

### **Recommended Fluid Viscosity Specifications:**

*ISO Viscosity Grades 22-46*

*cSt @ 40°C 22-46*

*cSt @ 100°C 4-8*

### **Recommended Fluid Maintenance:**

- ✓ Change hydraulic fluid after initial 100 hours of operation
- ✓ Change hydraulic fluid every 3000 hours of operation or 2 years thereafter.
- ✓ Check hydraulic fluid level regularly before operation

### **Note:**

ATF Dexron III does not have anti-foaming agent in fluid. Fluid aeration and cavitation can occur. Please make sure trailer is lowered or tilt deck is raised when adding fluid to reservoir.

### **Warning:**

Do not mix different grades and types of hydraulic fluids

### **Maintenance:**

- ✓ Change hydraulic fluid after initial 100 hours of operation
- ✓ Change hydraulic fluid every 3000 hours of operation or 2 years thereafter.
- ✓ Check hydraulic fluid level regularly before operation
- ✓ Check electrical connections regularly
  - ✓ Corrosion on all connections
  - ✓ Battery cables
- ✓ Load test battery often before use
- ✓ Cleaning
  - ✓ Never pressure wash or hose down the power unit. The DC motor is not sealed extended exposure to moisture will cause premature motor failure.
  - ✓ Spray light amounts of cleaner/degreaser on unit and dry with compressed air and/or rag.
  - ✓ Cleaning reservoir breather cap
    - Remove red cap from breather cap and clean filter element with dishwashing soap & water. Make sure the filter element is completely dry before installing back in the breather cap

### **Installation:**

#### **1. Filling reservoir**

- ✓ Notice two lines on dipstick of Breather cap
  - The top line indicates maximum fluid level
  - The bottom line indicated the minimum fluid level
- ✓ Fill reservoir to the top line on dipstick of breather during initial startup.
- ✓ Fill reservoir to fill line on dipstick after air has been cycled out of the system

## 2. Electrical

- ✓ **Reference the Battery Cable Selection Chart** to ensure the proper gage battery cable has been selected for power unit location
- ✓ **Never route electrical** around or across sharp edges that may cause chafing and damage to cable/wire insulation
- ✓ **Never route electrical** near moving parts that may chafe or pinch cable/wire

### ▪ Electrical Connections

- When tightening studded electrical connections. The nut only needs to be tight enough to collapse the spring lock washer.
- Ensure all spade connections are secure.
- Check electrical connect regularly for corrosion and tightness.

### ▪ Negative Cable from Battery/Ground

- Single terminal DC motors are internally grounded - Connect Negative cable from battery to the side of the DC motor.
- Two terminal DC motors have an isolated ground – The Battery cable must be connected to the Ground stud on the DC motor. (the stud with the cable connected to the start solenoid is the positive stud. The negative wire will have a ground wire connected to the start solenoid)

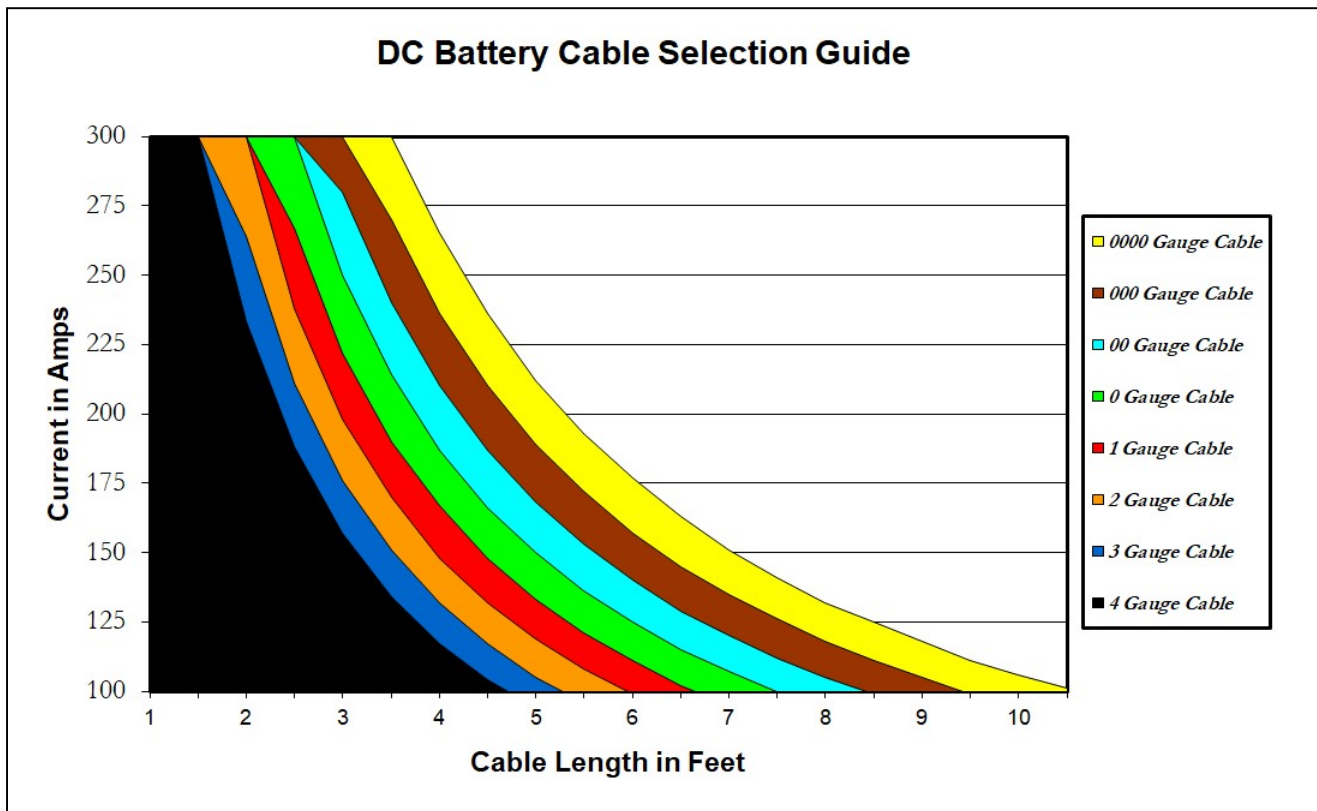

## Single Acting Schematic

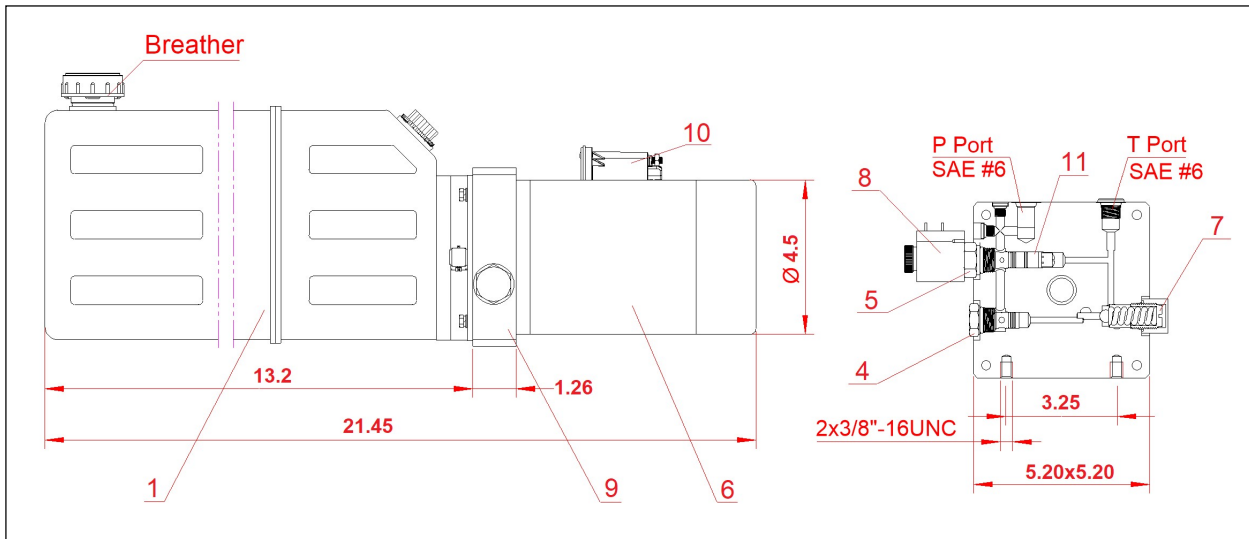
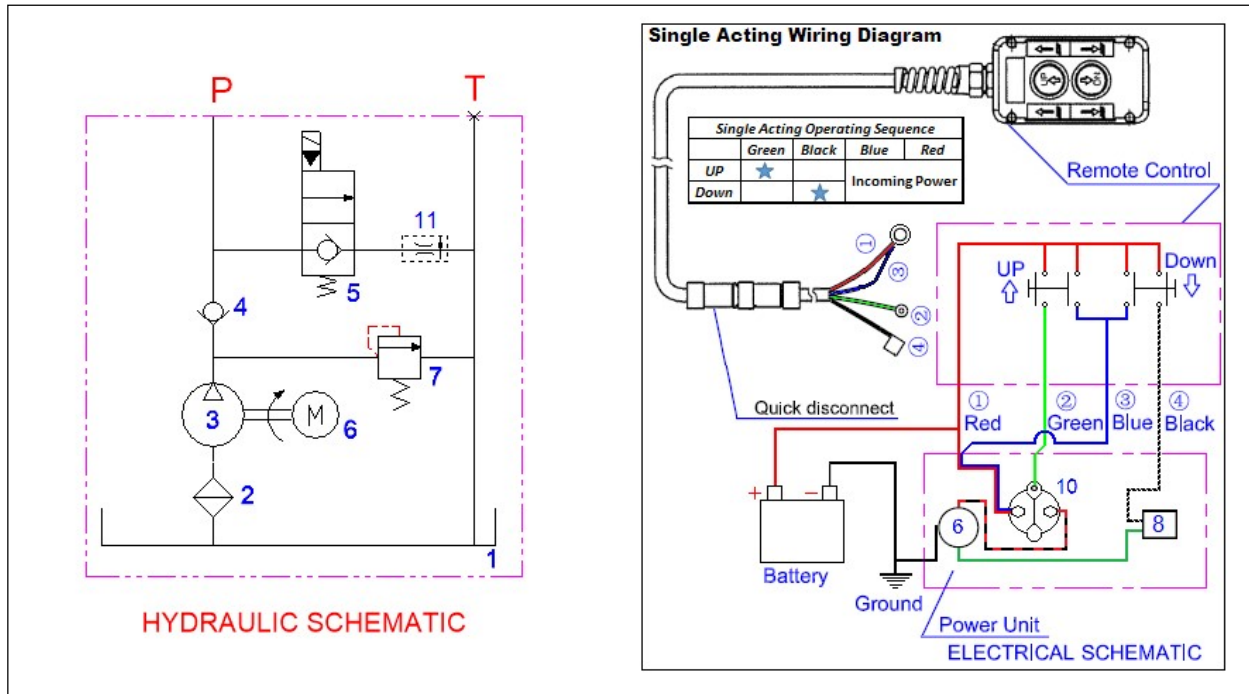

No.	Part Number	Description
1	622-0004	8 Quart poly Offset Reservoir
2	682-0019	Inlet Filter
3	204-0004	0.1324 cui-in/rev Gear Pump
4	632-0001	Check Valve
5	634-0002	Normally Closed 2-way
6	610-0004	12 Volt Single Stud DC motor
7	RV-3/4-A	Relief Set at 3200 psi
8	634-0008	10 Volt Dual Spade Coil
9	602-0004	End-Head/Manifold
10	684-0002	12 Volt Start Solenoid
11	636-0003	Flow Control Valve
	684-0008	2 Button Hand Control

## Troubleshooting

### Safety

This information is intended for use by a service technician who is familiar with hydraulic components & understands the required safety precautions. Please consult factory for any questions that may not be answered in this document.

### **WARNING:**

**IF THE PRESSURE RELIEF SETTINGS ARE TAMPERED WITH THE WARRANTY IS VOID**

When performing service on your DLH Fluid Power product you assume any and all responsibility for personal injury or property damage that may result.

Please read full equipment manual before attempting to troubleshoot and make repairs.

### Safety Precautions

- Tampering with relief valve
  - ✓ Tampering or adjusting the relief valve will void warranty, and could cause catastrophic failure which could result in equipment damage, severe injury or even death. **Adjusting the relief valve will not increase flow!**
- Hydraulic Fittings & Hoses
  - ✓ Always ensure hydraulic lines are not routed around or across sharp edges that may cause chafing and damage to hose.
  - ✓ Never crack or loosen a hydraulic connection under pressure. Doing so can result in a hydraulic injection. For more information on Hydraulic
  - ✓ Always follow the manufactures torque specifications for fittings and hoses.

Symptoms	Possible Cause	Correction	Special Notes
System Inoperative	Dead or Low Battery	Load test battery	Charge or replace battery
	Poor Ground	Ground battery directly to DC motor	Use jumper cables to jump ground only
	Dirty Contacts in Hand Control	Clean contact in hand control with eraser	Cleaning contacts with abrasive will cause frequent failure
	Corrosion on Battery Terminals	Inspect battery cables & clean battery terminals	Use of dielectric grease will prevent corrosion buildup
	Start Solenoid Failure	Jump Start Solenoid	Replace Solenoid
	Rust in DC Motor	Bypass Start Solenoid	If motor doesn't run after bypassing start solenoid, remove rear cover of motor for quick inspection.

<b>Symptoms</b>	<b>Possible Cause</b>	<b>Correction</b>	<b>Special Notes</b>
Motor Runs Load Not or Cylinder not Extending	Low Battery/ Poor Ground	Load test battery	Charge or replace battery
	Low fluid level	Add fluid to reservoir when cylinder is fully retracted	Unit can suck air from above fluid level when fluid level is low
	Pump Not Priming	Remove check valve & activate motor momentarily to prime.	Replace gear pump if problem is not solved
		<b>Check inlet on gear pump:</b> Inlet could be loose, missing or clogged with debris	Clean or replace inlet tube and filter if necessary
	Relief Valve	If relief valve is bypassing check pressure gage to ensure valve is set at proper setting as marked on power unit	Double check with equipment manufacturer ensuring the manufacturer did not adjust pressure setting at factory.
Cylinder	Check to see if fluid is coming out vent on rod end of cylinder when fully retracted	Rebuild or replace the cylinder if fluid is passing through the cylinder without moving the rod	

<b>Symptoms</b>	<b>Possible Cause</b>	<b>Correction</b>	<b>Special Notes</b>
Unit Struggles to Lift Load	Dead or Low Battery	Load test battery	Charge or replace battery
	Poor Ground	Ground battery directly to DC motor	Use jumper cables to jump ground only
	Rust in Motor	Bypass Start Solenoid	If motor doesn't run at a higher RPM after bypassing start solenoid, remove rear cover of motor for quick inspection.
	Worn seals in cylinder	Packing on piston of cylinder could be bad and be wedged against bore of cylinder.	Have cylinder tested by certified technician

<b>Symptoms</b>	<b>Possible Cause</b>	<b>Correction</b>	<b>Special Notes</b>
Reservoir Overflows When Lowering	Low fluid level	Add fluid to reservoir when cylinder is fully retracted	Before running power, unit ensure all air bubbles have dissipated to prevent further aeration of fluid
	Loose Inlet	Remove reservoir & tighten or replace inlet tube on pump	
	Reservoir too small for hydraulic system	Consult equipment manufacturer for correct reservoir size	

<b>Symptoms</b>	<b>Possible Cause</b>	<b>Correction</b>	<b>Special Notes</b>
Cylinder Not Retracting	Dead or Low Battery	Load test battery	Charge or replace battery
	Poor Ground	Ground battery directly to DC motor	Use jumper cables to jump ground only
	Coil on Solenoid Valve not Activating	Ensure power is getting to coil, check all electrical connections and check for magnetism	Replace coil if you are getting power to the coil but it is not energizing.
		Check ground wire or valve stem. For loose connections or corrosion. <i>(If coil is single wire lead, check the contacting point where solenoid rests on valve stem for corrosion)</i>	
		Loose wire in quick connector or control box	
		Clean contact in hand control with eraser	
	Bent stem on solenoid valve	Inspect stem on solenoid valve <b>(DO NOT REMOVE VALVE FOR INSPECTION IF SYSTEM IS UNDER PRESSURE)</b>	Replace valve if stem is bent
	Debris in screen of load holding valve	Remove load holding valve. Inspect screen & valve for debris. <b>Caution:</b> <i>load holding valve is below fluid level removing will partially drain reservoir. Warning: Do not remove valve is system is under pressure.</i>	Use dipstick on power unit to manually shift the valve. This is accomplished by inserting the dipstick in the nose of the valve and applying pressure. Replace valve if it doesn't shift.
	Debris in flow control valve	Remove flow control valve & inspect and remove any debris in valve	Top of valve is threaded, use 1/4-20 bolt with a minimum length of 2" to remove flow control valve.
	Cylinder issue	Fluid coming out vent on rod end of cylinder	Replace cylinder
Check cylinder alignment		Contact equipment manufacturer if this is an issue	
Packing in cylinder may have failed		Contact equipment manufacturer for replacement cylinder	